

UDC 532.5

COMPARISON OF OPERATION OF PHYSICAL AND SIMULATION MODEL OF PROPORTIONAL DISTRIBUTOR

V. ARTEMIEV, A. NEVZOROVA

Gomel State Technical University named after Sukhoi, Belarus

The paper presents the development of a test bench for a proportional valve using Festo equipment and a simulation of the bench operation in the Fluidsim software. Analysis of the data obtained allows us to conclude that the developed simulation model adequately describes the behavior of a real object.

Introduction. Modern hydraulic drives are complex mechatronic systems, in the design of which it is necessary to take into account the operation of the hydraulic drive itself, the electronic control system, the kinematics and dynamics of the machine movement. The creation of a new technical object is a complex and time-consuming process, in which the design stage is of decisive importance in the implementation of the idea and achievement of a high technical level. Modeling is one of the most important stages in the design of any technical object, including modern hydraulic systems, allowing you to replace or significantly reduce the stages of adjustment and field tests [1].

To simulate the operation and control of hydraulic drive systems, a program developed by Festo Didactic is used in most part to design hydraulic drive and hydraulic circuits with manual, electric and electronic control [2]. Such a program makes it possible to study the work of the compiled circuits in various modes using animation [3, 4].

Simulation modeling makes it possible to solve the problems of control, regulation, statics, kinematics, dynamics and power engineering of hydraulic mechanisms from a single methodological point of view and represents the unifying core of the calculation complex.

Purpose of work - to create a physical model of a test bench for a proportional valve of wide application using Festo equipment and to simulate the operation of the bench in the FluidSim software.

Research methods. For the development of the stand, instrumentation was used, as well as hydraulic control equipment and a tested hydraulic valve from Festo.

For the test bench, I-30A oil was used. The preparation of the research began with the preparation of the liquid - heating (cooling) to a given temperature.

The stand of the hydroelectric power station was located in a room with an ambient temperature of 5 ± 2 °C. providing conditions close to the working one. When the pump is turned on, the oil overflows through the safety valve (Fig. 1, item 1), due to which it gradually heats up to the required temperature. The liquid temperature is monitored by a tank thermometer and a temperature sensor (fig. 1, pos. 4). Then the oil enters the battery capacity, while the battery is being charged (Fig. 1, pos. 6). As soon as the heating of the fluid reaches the required temperature, the hydraulic unit is turned off. In this case, the valve spool is brought to the closed position, the oil value is set.

With the closed position of the valve spool (Fig. 1, item 3), the amount of fluid leakage was determined.

With the help of the control device (pos. 11 Fig. 1), the proportional magnet of the valve was used to regulate the value of the current at which the movement of the valve spool begins, which corresponds to the force of displacement of the spool in a directly proportional relationship.

To determine the time moment of the start of movement of the distributor spool, a flow meter was used (item 2, Fig. 1), since when the spool is displaced, the fluid passage into the control line of the distributor opens. The readings of the control and measuring devices were displayed in real time on a computer monitor. Measurements for each experiment were carried out 3 times with constant specified parameters.

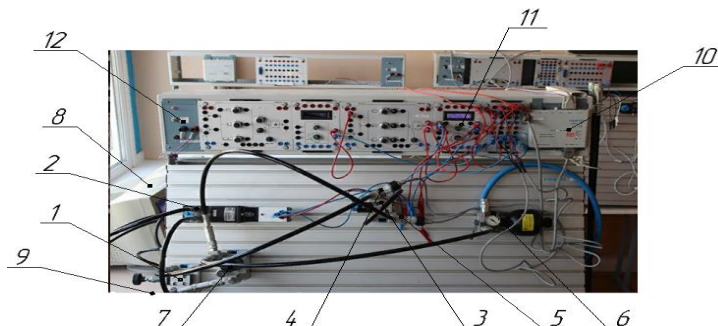

- 1 - pressure valve; 2 - flow meter (0 - 10 V, 0-10 l / min); 3 - tested valve; 4 - temperature sensor (20-30V, 0-100 ° C);
 5 - pressure sensor (15 - 30V, 10 MPa); 6 - battery (6 MPa); 7 - filter (5 μ m); 8 - personal computer (PC);
 9 - pumping station; 10 - analog converter providing communication with PC;
 11 - proportional magnet control device, 12 - power supply

Fig. 1. – Research stand

Technology, Machine-building

Then, based on the physical model of the stand, a simulation model was developed in the form of a hydraulic circuit (Fig. 2) and its operation was checked. This simulation model allows you to see how oil flows through the system and how the valve spool opens.

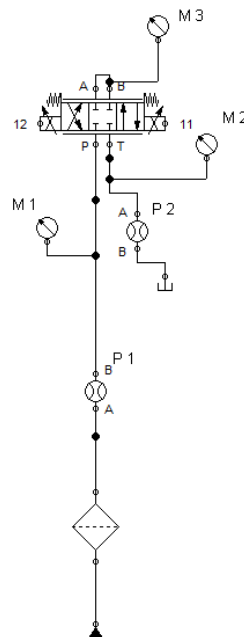

Fig. 2. – The created circuit in the FluidSim program

Results. The following was taken as the initial data: oil consumption 5 l / min and pressure 2.5 MPa. The results of the physical model (Fig. 3) and the simulation model (Fig. 4) were compared.

According to the work of the test bench of the proportional distributor, the following indicators were obtained:

- flow rate 2.5 l / min;
- pressure at the inlet, after the distributor and at the outlet from 2 to 3 bar.
- temperature 2.50C.

According to the work of the simulation model of the proportional valve test bench:

- flow rate from 0 to 5 l / min;
- inlet pressure from 0 to 2.5 MPa;
- pressure after passing through the distributor from 0 to 1.2 MPa;
- outlet pressure from 0 to 0.0035.

By establishing the adequacy, the result did not reveal design and technical errors in the real and simulation schemes. The formulated simulation model allows you to obtain a high level of adequacy in the study of the scheme using the algorithm of the FluidSim program.

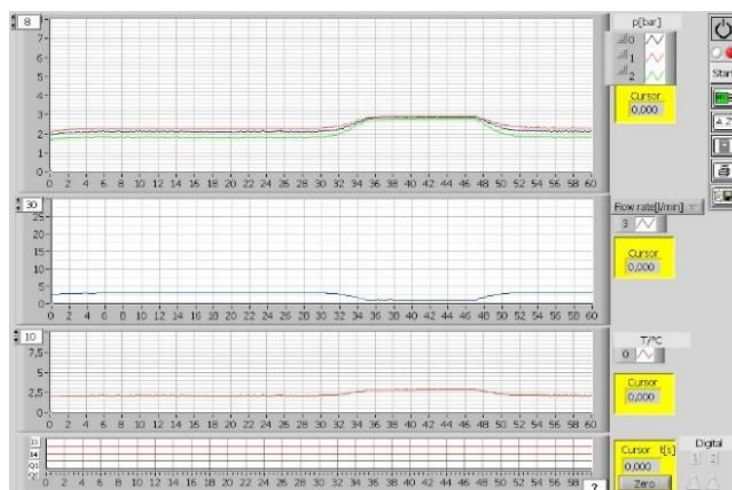

Fig. 3. – Screenshot of test bench measurements

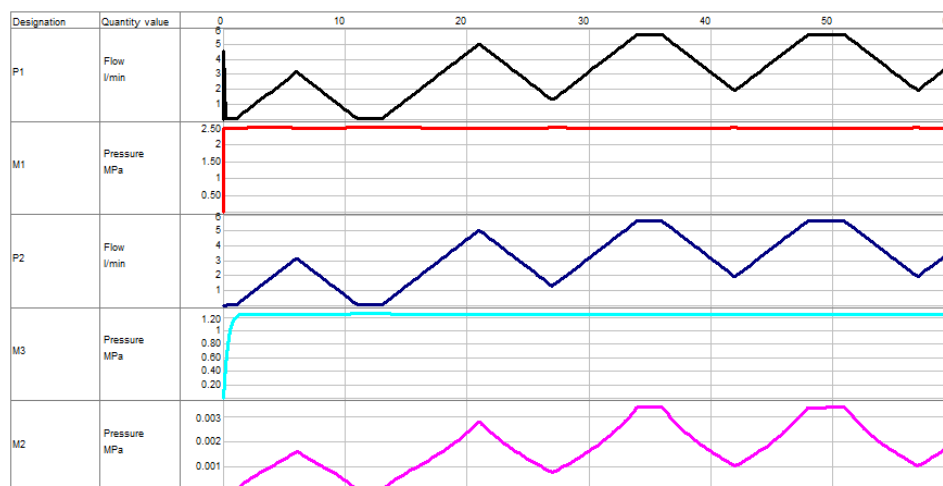

Fig. 4. – The result of the simulation model of the created program FluidSim

Conclusion. Based on the results obtained, we conclude that the developed calculation method allows us to build a simulation model that correctly reproduces the operation of the distributor regulator in a given hydraulic system (at the stand), and the results obtained allow us to understand some subtle points in the specifics of its work, which is of practical interest and can be used in mechanical engineering, machine tool building, and combine building to simulate the work of the designed hydraulic units.

REFERENCES

1. Shornikov Yu. V., Myandin S. A. Computer modeling of hydraulic systems // Young Scientist. - 2017. - No. 22. - S. 104-110.
2. Borovikov A.V. Research of hydraulic drive operation using fluidsim program // International student scientific bulletin. - 2019. - No. 5-1.
3. Sbrodov, N.B. Design and modeling of electropneumatic automation systems. Methodical instructions for practical exercises. - Kurgan, 2015.-30 p.
4. Hydro-pnevmo.ru. Calculations, design. Design documentation. In which program to create hydraulic and pneumatic circuits. [Electronic resource] - Access mode: <http://www.hydro-pnevmo.ru/topic.php?ID=7...> - Date of access: 13.04.2021.